

Application Number: F/YR12/0575/F

Minor

Parish/Ward: Whittlesey/Benwick, Coates, Eastrea

Date Received: 31 July 2012

Expiry Date: 25 September 2012

Applicant: Mr J Brown

Agent: E C Brown and Son

Proposal: Erection of a 36.4m high (hub height) 50 kw wind turbine and control unit

Location: Land North of Wypemere Farm 257 Benwick Road, Whittlesey

Site Area/Density: 293 sq metres

Reason before Committee: This proposal is before the Planning Committee as it is in the wider interest.

1. EXECUTIVE SUMMARY/RECOMMENDATION

The proposed wind turbine has an overall height of 46 metres. The proposal is considered to accord with national regional and local planning policy in contributing to the need for renewable energy. However, the application is not supported by adequate biodiversity information to enable a full consideration of the application, no auto-tracking information has been submitted to indicate whether or not temporary works are necessary to the public highway in order to gain a satisfactory access to the site and the applicant has submitted inadequate information - particularly in the form of visual representations to enable a full consideration of the application - accordingly the application is recommended for refusal.

2. HISTORY

Of relevance to this proposal is:-

2.1	F/YR11/0794/F	Erection of 1 x 36.4 metre high (hub height) wind turbine – Staffurths Bridge Farm	Granted 19 December 2011
	F/YR/09/0272/F	Erection of 9 x 67 metre high (hub height) wind turbines and met mast land north of Floods Ferry Farm	Refused on 04/01/2010
	F/YR/09/0392/F	Erection of 3 no wind turbines (max height 100 m to blade tip) Land North Of Burnthouse Farm	Allowed on appeal
	F/YR09/0562/F	Erection of 5 wind turbines (110m to blade tip) Boardinghouse Farm, Knights End Road, March	Allowed on appeal 06 July 2011
	F/YR07/0585/SCO	Wind Farm Screening Opinion	Further details required
	F/YR/06/0594/F	Erection of 2 no wind turbines (max height 100 m to blade tip) Ransonmoor Farm	Granted – 23 February 2007

F/YR/03/0990	Erection of 3 no wind turbines (max height 100 m to blade tip) Ransonmoor Farm	Granted – 25 April 2005
F/YR12/0207/F	Erection of 1 no Turbine - Land North of Floods Ferry Farm, March	Refused – August 2012

3. **PLANNING POLICIES**

3.1 **National Planning Policy Framework:**

Paragraph 2: Planning law requires that application for planning permission must be determined in accordance with the development plan.

Paragraph 14: Presumption in favour of sustainable development.

Paragraph 93: Meeting the challenge of climate change, flooding and coastal change.

Paragraph 109: Conserving and enhancing the natural environment.

Paragraph 98: Need for renewable energy and acceptable impacts.

3.2 **Draft Fenland Core Strategy July 2012:**

CS12: Responding to climate change and managing the risk of flooding in Fenland.

CS14: Delivering and Protecting High Quality Environments across the District.

3.3 **Fenland District Wide Local Plan:**

EMP1: Proposals will normally be favoured for new, or the extension or expansion of existing firms ... outside DABs the expansion of existing firms will only be permitted where certain criteria are satisfied.

E1: To resist development likely to detract from the Fenland landscape. New development should meet certain criteria.

E8: Proposals for new development should: allow for protection of site features, be of a design compatible with their surroundings, have regard to amenities of adjoining properties and provide adequate access.

E20: To resist any development which by its nature gives rise to unacceptable levels of noise, nuisance and other environmental pollution.

E3: To retain existing trees and hedgerows. To impose, where appropriate, conditions on planning applications requiring landscaping and tree planting schemes. To request the submission of a landscaping scheme with planning applications on visually important sites.

3.4 **East of England Plan:**

SS1: seeks to bring about sustainable development

ENG2: The development of new facilities for renewable power generation should be supported with the aim that by 2010 10% of the region's energy, and by 2020 - 17%, should come from renewable sources (excluding energy from offshore wind)

ENV2: Planning Authorities should protect and enhance the diversity and local distinctiveness of countryside character by developing area-wide strategies and landscape character assessments to ensure development respects/enhances local landscape character.

ENV3: Ensure that new development minimises damage to biodiversity.
Policy ENV4: Ensures that the landscape, historic and wildlife value of farmland is increased whilst responding to issues such as climate change.
ENG1: Carbon dioxide emissions and energy performance.
SS1: Achieving sustainable development.

3.5 The Fenland Wind Turbine Development Policy Guidance June 2009 (WTDPG)

Details contained under assessment section.

4. CONSULTATIONS

- | | | |
|-----|---------------------------------------|---|
| 4.1 | Town Council: | No response at time of writing report |
| 4.2 | CCC Crime Prevention | No Objections |
| 4.3 | Local Highway Authority (CCC): | The length of the articulated vehicle delivering the turbine unit will be in excess of 40ft. The left turn into Wype Drove from Benwick Road for such a vehicle will be very tight. An auto - track template for the vehicle turn at this junction therefore needs to be provided in order to establish whether any temporary widening of this junction is required in order for this vehicle to safely negotiate this junction. Should such temporary works to the junction prove to be necessary then the details will have to be agreed with the Area Maintenance Engineer and then carried out by the applicant under an appropriate agreement. |
| 4.4 | CAA | No objection – advice offered |
| 4.5 | Middle Level Commissioners | No comments to date |

4.6 **Environmental Health**

The following conditions should be added to a planning permission should it be granted.

Night-time noise levels

The noise emission (LA90, 10 minute) from effects of the wind turbine, as measured in free field conditions at any dwelling, shall not exceed during night hours 2300 – 0700, the greater of 43dB(A) or 5dB(A) above the night hours background noise (LA90, 10 minute) as measured in accordance with ETSU-R-97.

Day-time noise levels

At all other times the noise emission (LA90, 10 minute) from the effects of the wind turbine, as measured in free field conditions at any dwelling, shall not exceed the greater of 35dB(A) or 5dB(A) above the Quiet Waking Hours background noise (LA90, 10 minute) at wind speeds within the site not exceeding 10 metres per second.

Informative:

Period of hours have been used are as defined in ETSU-R-97 (The Assessment and Rating of Noise from Wind Farms).

Quiet day-time periods are defined as:

All evenings from 6pm to 11pm,

Plus Saturday afternoons from 1pm to 6pm,

Plus all day Sunday, 7am to 6pm.

Night-time is defined as 11pm to 7am

Remedial Action

In the event that noise exceeds the limits specified in the planning permission remedial Action must be undertaken to reduce the noise levels. This would include, checking the source noise level of individual turbines (if this has not already occurred as part of any warranty agreement with the turbine supplier or by compliance testing). Mitigation applied may involve slowing of turbine rotational speed, thus reducing noise, or even shut-down of individual turbines, under critical wind conditions.

Operator monitoring

At the reasonable request of, and following a complaint to, Fenland District Council the operator of the development shall, measure and assess the level of noise emissions from the wind turbine generators, following the procedures described in “The Assessment and Rating of Noise from Wind Farms, ETSU-R-97” published by ETSU for the Department of Trade and Industry.

Cumulative impact

Monitoring undertaken to identify compliance of planning conditions or justify complaints must consider the cumulative impact of other wind farms / turbines. The existence of other wind farm noise should not be considered as part of the prevailing background noise.

Operator monitoring

At the reasonable request of, and following a complaint to, Fenland District Council the operator of the development shall, measure and assess the level of noise emissions from the wind turbine generators, following the procedures described in “The Assessment and Rating of Noise from Wind Farms, ETSU-R-97” published by ETSU for the Department of Trade and Industry.

Cumulative impact

Monitoring undertaken to identify compliance of planning conditions or justify complaints must consider the cumulative impact of other wind farms / turbines. The existence of other wind farm noise should not be considered as part of the prevailing background noise.

- 4.7 **Environment Agency** No objections – advice offered
- 4.8 **NERL Safeguarding** Does not conflict with safeguarding criteria
- 4.9 **Chatteris Airfield** No objection
- 4.10 **CCC Rights of Way** No objection
- 4.11 **Anglian Water** No objection
- 4.12 **Local residents/interested parties** 1 letter of objection has been received raising the following issues
- surely lots of solar panels would suffice
 - encroachment on residential areas
 - blot on landscape near villages like Eastrea and Coates
 - may create background noise and hazard to local residents
- Natural England** No objection – advice offered

5. SITE DESCRIPTION

- 5.1 The site is situated on agricultural land approximately 450 metres from Wypemere Farm. Other properties surrounding the site are in excess of 400 metres

6. PLANNING ASSESSMENT

6.1 Nature of Application

The application seeks full planning permission for the erection of a 3 bladed wind turbine assembly with an overall height of 46 metres to the top blade tip. The turbine will be used to generate electricity to reduce the farms reliance on fossil fuels, energy bills and carbon emission. Access will be via the existing farm access roadway which serves Wypemere Farm.

The following key issues have been considered;

- Site history
- Principle and policy implications
- Visual Impact/Landscape Impact/Cumulative Visual Impact
- Biodiversity
- Design
- Access

Site History

There is a planning history of wind turbine development to the south east of the site which is highlighted above and to the south west at Glassmoor.

Principle and Policy Implications

The proposal has been considered in line with National Guidance, in the form of the new National Planning Policy Framework (NPPF) and Development Plan Policy in the form of the Fenland District-Wide Local Plan, 1993, the East of England Plan and also the new Fenland Communities Development Plan Draft Core Strategy; these are listed in the relevant section of this report.

The Government has set a target of generating 20% of the UK's electricity by 2020 and also aims for the UK to be on a path to cut its carbon dioxide emissions by 60% by 2050, as well as maintaining reliable and competitive energy supplies. The development of renewable energy is considered to form a key part of meeting this target which has led to the view that renewable energy schemes should be supported where they do not result in other adverse impact upon the area that outweigh the renewable energy benefits. This application is for the erection of a wind turbine and associated infrastructure. Wind turbines are a sustainable and efficient source of renewable energy and therefore comply, in principle, with the provisions of the NPPF and emerging Core Strategy.

The Fenland Wind Turbine Development Policy Guidance June 2009 (WTDPG)

This document provides local guidance in relation to wind turbine development. It is recognised that there is a need to ensure that future development is in balance with the local landscape and the population that lives within it. As a result the Wind Turbine Development Policy Guidance (WTDPG) was produced by landscape consultants for FDC in April 2008. The WTDPG has been adopted as supplementary planning guidance by the Council. The WTDPG sets down a number of landscape character types and then sets out criteria for evaluating the sensitivity of each type.

Section 6 sets out the criteria for assessing planning applications based on:

- *Landscape character*
- *Landscape capacity*
- *Visual impacts*
- *Cumulative landscape impacts*
- *Cumulative visual impacts*
- *Biodiversity considerations*
- *Heritage considerations*
- *Recreation and transport routes*
- *Mitigation*
- *Guidance on Form and Siting*

Where wind turbine development is considered appropriate in the light of the above criteria, schemes should then be considered in terms of how the form and siting of turbine(s) should relate to the characteristics of the landscape type in which it is to be situated. Under the above guidance the proposed site is situated within the following designations:

- 1 *“The Fens” landscape character area which has a medium - high landscape capacity for groups of 17+,*
- 2 *A high landscape capacity for single turbines*
- 3 *A high landscape capacity for small turbine groups (2-5),*
- 4 *A high landscape capacity for small/medium turbine groups (6-10),*
- 5 *A medium-high landscape capacity for medium turbine groups (12-16),*
- 6 *A medium-high landscape capacity for large turbine groups (17+),*
- 7 *Within the 5km conspicuous zones for existing turbines,*
- 8 *Within the 2km ‘prominent’ zone for existing and proposed turbines.*

In terms of landscape capacity within the Drained Fenland character type the WTDPG advises that the “cumulative impact of wind turbine development needs to be carefully considered”.

In terms of visual impact the WTDPG advises that:

- *Proposals within 400m of a settlement are highly unlikely to be considered*

acceptable in visual amenity terms.

- *There should be no shadow flicker for any residential properties or on A or B roads.*
- *Proposals within 2km of a settlement should be carefully considered as turbines are likely to be highly prominent features*
- *Turbines should be set back a minimum distance of 200m from public footpath). The WTDPG advises that for National Trails this should be 3 times the distance of the overall height of the turbine.*
- *Residential properties and users of recreational routes/facilities are likely to be considered more sensitive as receptors.*

In terms of cumulative landscape impact the WTDPG advises that that there is a danger that excessive development of wind turbines in any landscape would at some point result in such material change as to unbalance and overpower the existing key characteristics of the landscape. To prevent this it advises that within the Drained Fenland character type not more than 25% of the area should be within 2km of a turbine development (prominent zone) and not more than 75% within 5km (conspicuous zone).

- *Proposals for new wind turbine development, detached from existing turbines sites by more than 500m but within 4km of existing turbine developments are unlikely to be acceptable in visual terms. In some circumstances a distance greater than 500m is required.*
- *Proposals for new development within 10km of existing turbine developments need to be carefully considered.*
- *Settlements of more than 10 dwellings should not have wind turbines in more than 90° of their field of view from public or residential viewpoints within or around the settlements from a distance of 10km from the settlement.*
- *No more than 25% of the length of A and B roads and railways should be within 2km of wind turbines (prominent zone) and no more than 75% of its length being within 5km of turbines (conspicuous zone)*
- *Turbines within 4km of each other are likely to demonstrate a significant cumulative impact from a number of locations and are less likely to be considered acceptable in visual/landscape terms, unless they form a relatively modest extension to an existing turbine development.*

Visual Impact/ Landscape Impact/Cumulative Visual Impact

The site is not located within any national or locally designated landscape areas. The nearest residential property is situated at a distance of approximately 400/450 metres from the application site. The turbine would be highly visible in the immediate locality and is in an isolated position and within 2km of a settlement where turbine proposals should be carefully considered as they are likely to be highly prominent features. It is therefore important to consider the impact of the turbine on the overall appearance of the Fenland landscape in terms of visual impact, landscape impact and cumulative visual impact. The applicant has submitted inadequate information, particularly in the form of visual representations to enable a full consideration of the application in terms of both short and long distance views and accordingly a case has not been made as to why planning permission should be granted.

Biodiversity

The biodiversity checklist indicates that no surveys have been undertaken for protected species yet it is stated that there is no evidence of protected species in the area. This is misleading and of concern that the planning application is not supported

by a proper biodiversity assessment. In the absence of such an assessment planning consent should not be granted.

Design

Shadow flicker created by the turning of the turbine blades at certain times of day should also be considered. In terms of this proposal the impact is considered to be minimal given the proximity of the nearest property. It is unlikely that there will be noise impact from the turbine.

Access

Access to the site would be via the road serving the existing farm. However, the length of the articulated vehicle delivering the turbine unit will be in excess of 40ft and the left turn into Wype Drove from Benwick Road for such a vehicle will be very tight. An auto-track template for the vehicle turn at this junction therefore needs to be provided in order to establish whether any temporary widening of this junction is required to enable this vehicle to safely negotiate the junction. In the absence of auto-tracking information indicating whether or not temporary works are necessary to the highway in order to facilitate the safe passage of the delivery vehicle, planning consent should not be granted.

7. CONCLUSION

- 7.1 The proposed wind turbine has an overall height of 46 metres. The proposal is considered to accord with national regional and local planning policy in contributing to the need for renewable energy. However, the application is not supported by adequate biodiversity information to enable a full consideration of the application, no auto-tracking information has been submitted to indicate whether or not temporary works are necessary to the public highway in order to gain a satisfactory access to the site and the applicant has submitted inadequate information - particularly in the form of visual representations to enable a full consideration of the application - accordingly the application is recommended for refusal.

8 RECOMMENDATION

Refuse Planning Permission the following reasons:-

1 The application is not supported by an adequate biodiversity survey in order to assess whether or not there is evidence of protected species in the area and is therefore contrary to Section 11 of the National Planning Policy Framework

2 No auto-tracking information has been submitted for a suitable route to indicate whether or not temporary works are necessary to the public highway in order to gain a satisfactory access to the site for construction proposes – accordingly the scheme is considered contrary to Policy E8 of the Fenland District Wide Local Plan.

3 The proposal contains inadequate and unrepresentative information, particularly in the form of visual representations, to enable a full and proper consideration of the application in respect of both short and long distance views.

Location Plan - Wypemere Farm

Scale: 1:2,500

Proposed Turbine Location: 530542/296444

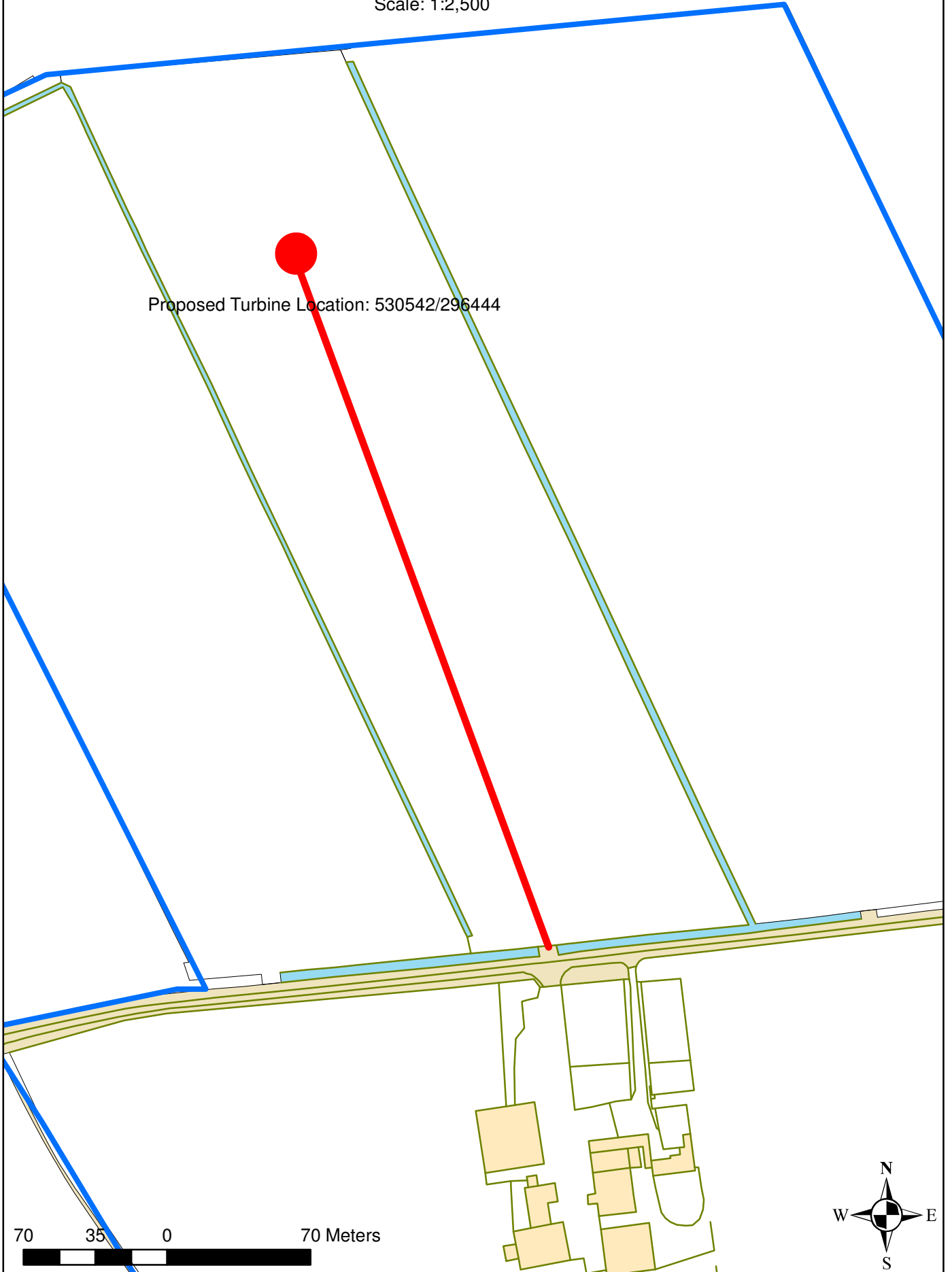

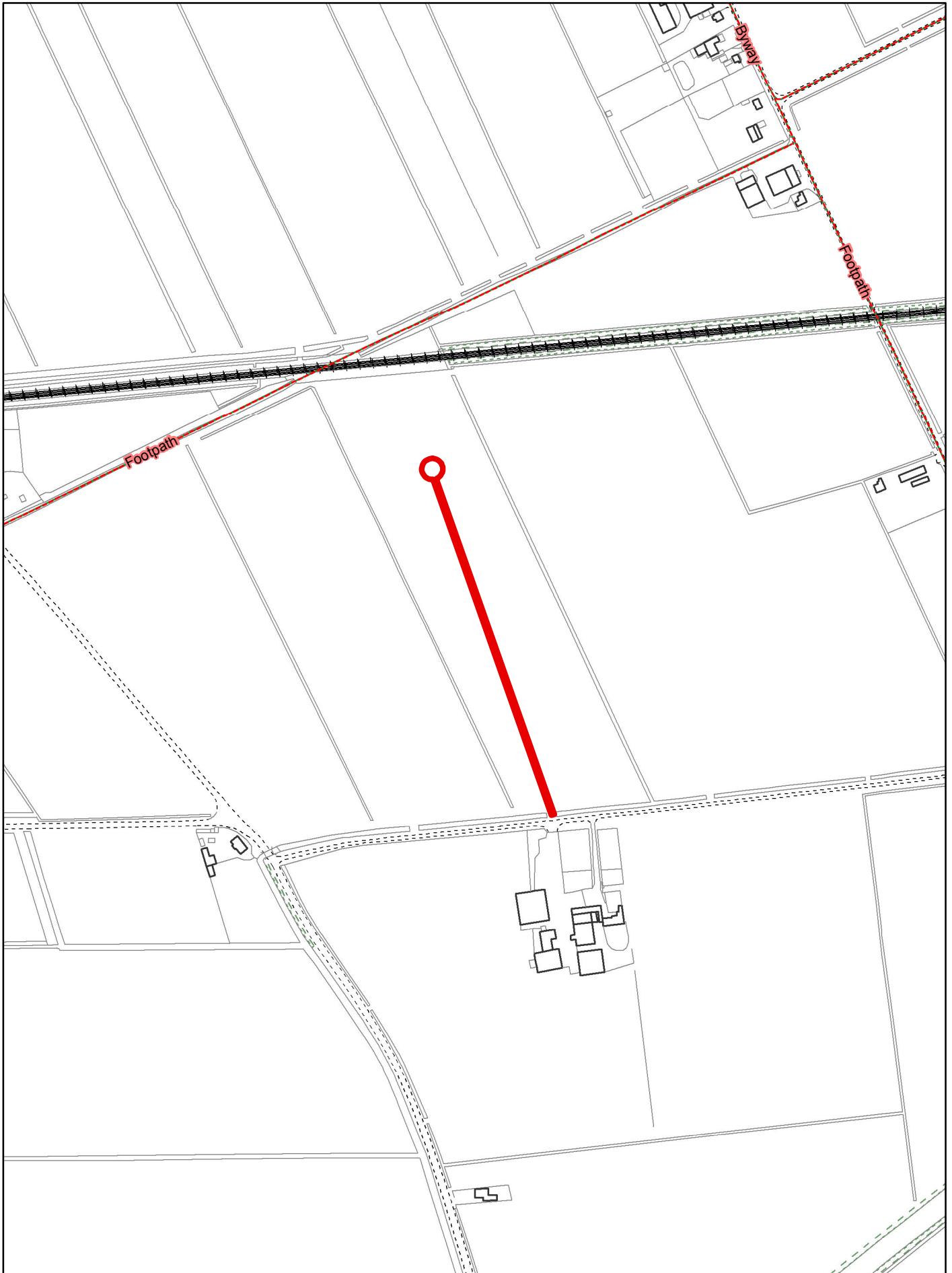

Created on: 08/08/2012

© Crown Copyright and database rights 2012 Ordnance Survey 10023778

F/YR12/0575/F

Scale = 1:5,000



Endurance E-3120 36m Scaled Elevation Drawing

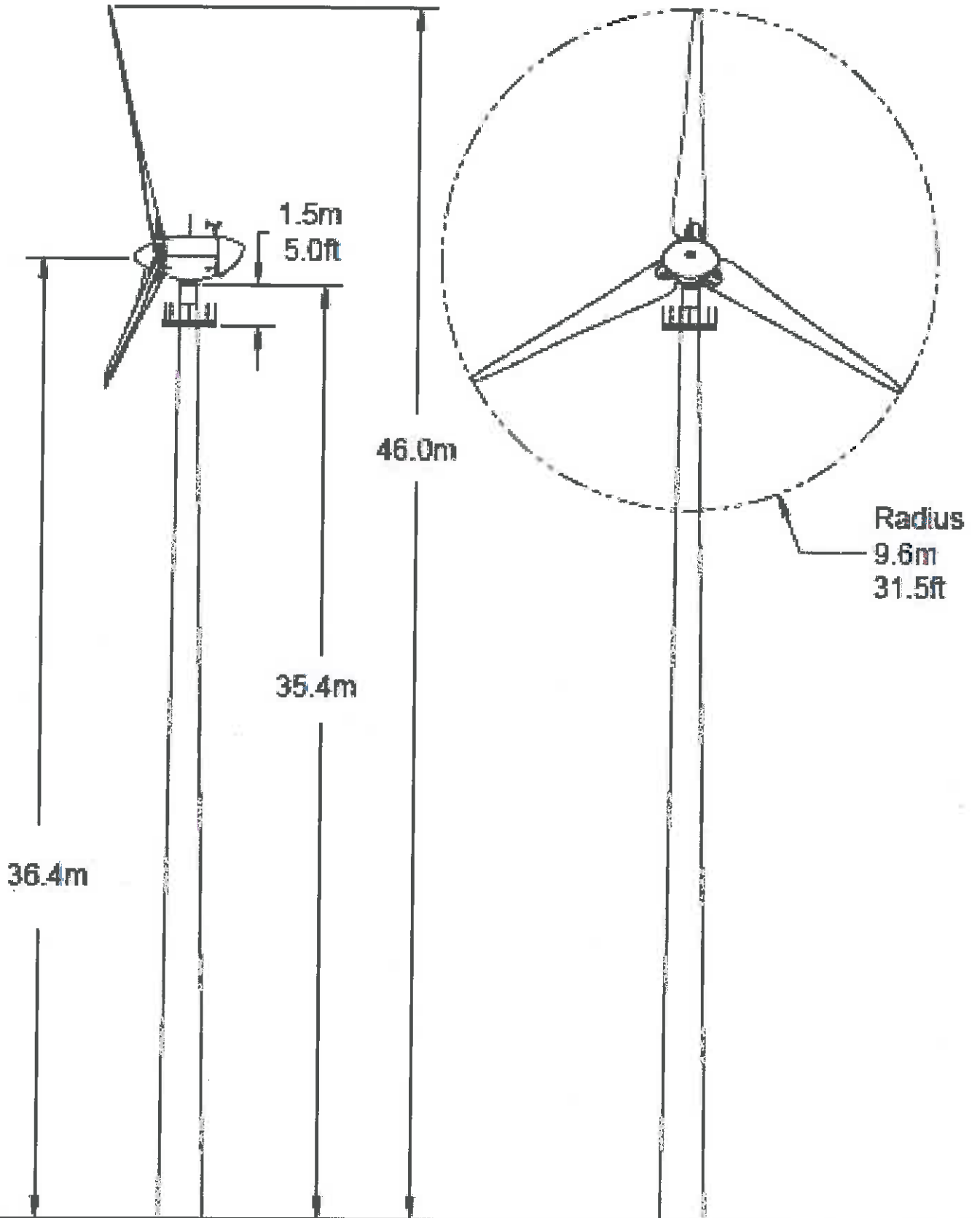

Scale 1:200 at A4